

Double Low Head Type Hoist (Creep)

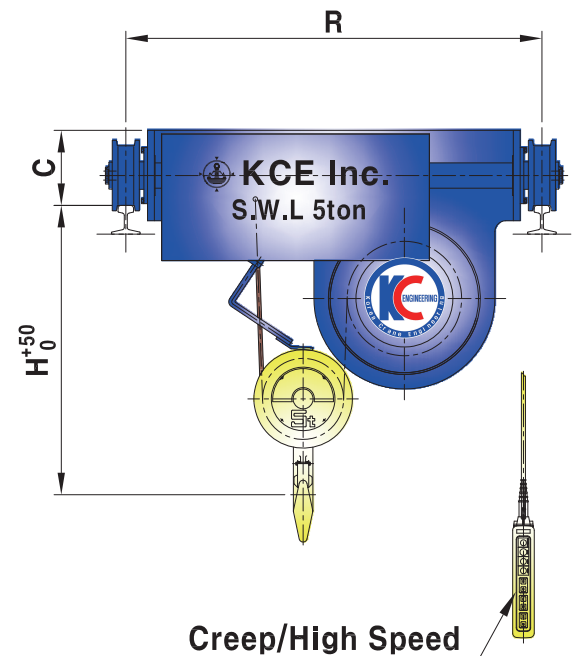
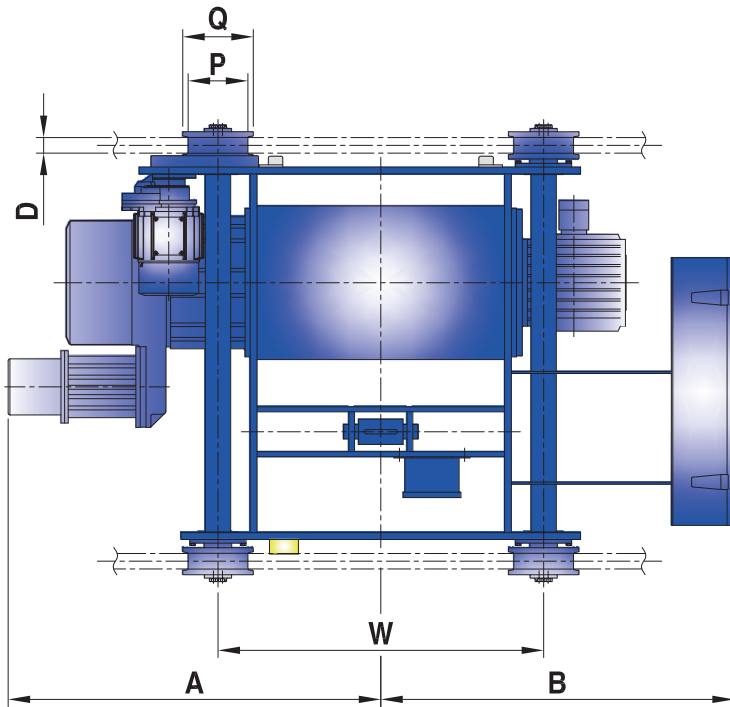

Creep/High Speed

Capacity (ton)		2	3	5	7.5	10	15	
Model No.		DL02-C-H06	DL03-C-H06	DL05-C-H06	DL075-C-H12	DL10-C-H12	DL15-C-H12	
Hoisting	Lift Height (m)	6	6	6	12	12	12	
	Speed (m/min)	50 (Hz)	8.4/0.84	7.5/0.75	4.7/0.47	3.1/0.31	3.7/0.37	3.7/0.37
		60 (Hz)	10/1	9/0.9	5.6/0.56	3.8/0.38	4.5/0.45	4.5/0.45
	Motor (kWxP)	3.7/0.4x4	5.5/1.1x4	5.5/1x6	5.5/1x6	9/1.1x8	13/1.8x8	
	Wire Rope [Φ x Falls]	Construction	6x37	6x37	6x37	6x37	6x37	6x37
Dia.(mm) x No. of ropes		8x4	9x4	11.2x4	14x4	16x4	20x4	
Brake		DC Magnet Disc Brake						
Traversing	Speed (m/min)	High 50/60 (Hz)	20/24	20/24	20/24	12.5/15	12.5/15	12.5/15
		Low 50/60 (Hz)	13/16	13/16	13/16	8.3/10	8.3/10	8.3/10
	Motor (kWxP)	High	0.75x4	0.75x4	0.75x4	0.75x4	0.75x4	1.5x4
		Low	0.5x6	0.5x6	0.5x6	0.5x6	0.5x6	1x6
Dimension (approx.) (mm)	H	400	495	600	950	920	1250	
	R	950	950	1150	1400	1300	1700	
	A	775	870	950	1230	1230	1080	
	B	560	840	655	835	955	1009	
	C	170	170	205	300	240	260	
	W	750	650	840	1250	1250	1300	
	D	47	47	58	58	58	58	
	P	140	140	165	165	165	180	
Q	170	170	195	195	195	210		
Weight (approx.) (kg)		460	550	850	950	1300	1950	
Rail		15kg/m	15kg/m	15kg/m	15kg/m	15kg/m	15kg/m	

- All materials applied are suitable in specified ambient temperature.
- KCE Inc reserves the right to alter or amend the above information without notice.
- The size can be changed according to detailed design.