

## Load Block Ass'y

### 1TON(Mono-Rail Type)

KEY NO.	PART NO.	PART NAME	Q'TY	REMARKS	KEY NO.	PART NO.	PART NAME	Q'TY	REMARKS
00	114 100	Load Block Ass'y	1		12	114 109	Bearing Cover	2	
01	114 101	Hook	1		13	014 154	(+)-Screw	8	M5x30L
02	114 102	Sheave	1		14	021 151	Bearing	2	#6205ZZ
03	114 103	Frame	1		15	021 152	Snap Ring	1	R52
04	114 104	Hook Beam	1		16	114 110	Sheave Shaft	1	
05	014 251	Thrust Bearing	1	#51104	17	114 111	Sheave Cover	2	
06	114 106	Hook Nut	1		18	114 112	Bolt Cap	2	
07	014 107	Safety Latch	1		19	014 157	Spring Washer	2	M10
08	014 108	Spring	1		20	014 158	Bolt	2	M10x25L
09	014 152	Nut	1	M5	21	114 113	Name Plate	2	
10	014 153	Plate Washer	1	M5	22	114 151	Split Pin	1	Φ4x45L
11	014 154	(+)-Screw	1	M5x30L					

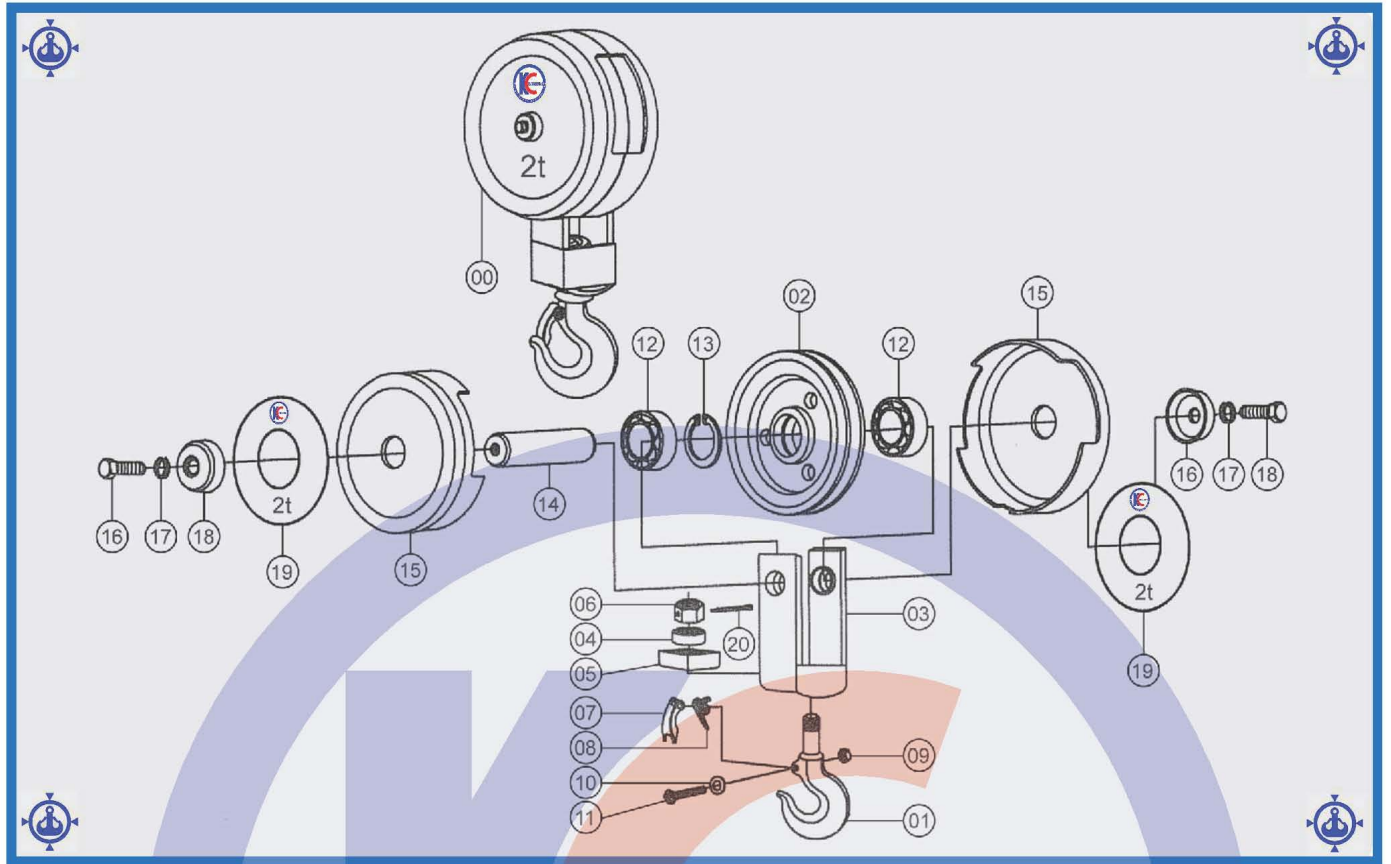

## Load Block Ass'y

### 2TON(Mono-Rail Type)

KEY NO.	PART NO.	PART NAME	Q'TY	REMARKS	KEY NO.	PART NO.	PART NAME	Q'TY	REMARKS
00	214 100	Load Block Ass'y	1		12	214 152	Bearing	2	#6207ZZ
01	214 101	Hook	1		13	214 253	Snap Ring	1	R72
02	214 102	Sheave	1		14	214 100	Sheave Shaft	1	
03	214 103	Frame	1		15	214 111	Sheave Cover	2	
04	214 151	Thrust Bearing	1	#51106	16	214 112	Bolt Cap	2	
05	214 105	Bearing Cap	1		17	211 051	Spring Washer	2	M16
06	214 106	Hook Nut	1		18	214 154	Bolt	2	M16x25L
07	214 107	Safety Latch	1		19	214 113	Name Plate	2	
08	214 108	Spring	1		20	214 155	Split Pin	1	Φ4x45L
09	014 152	Nut	1	M5					
10	014 153	Plate Washer	1	M5					
11	014 154	(+)Screw	1	M5x45L					

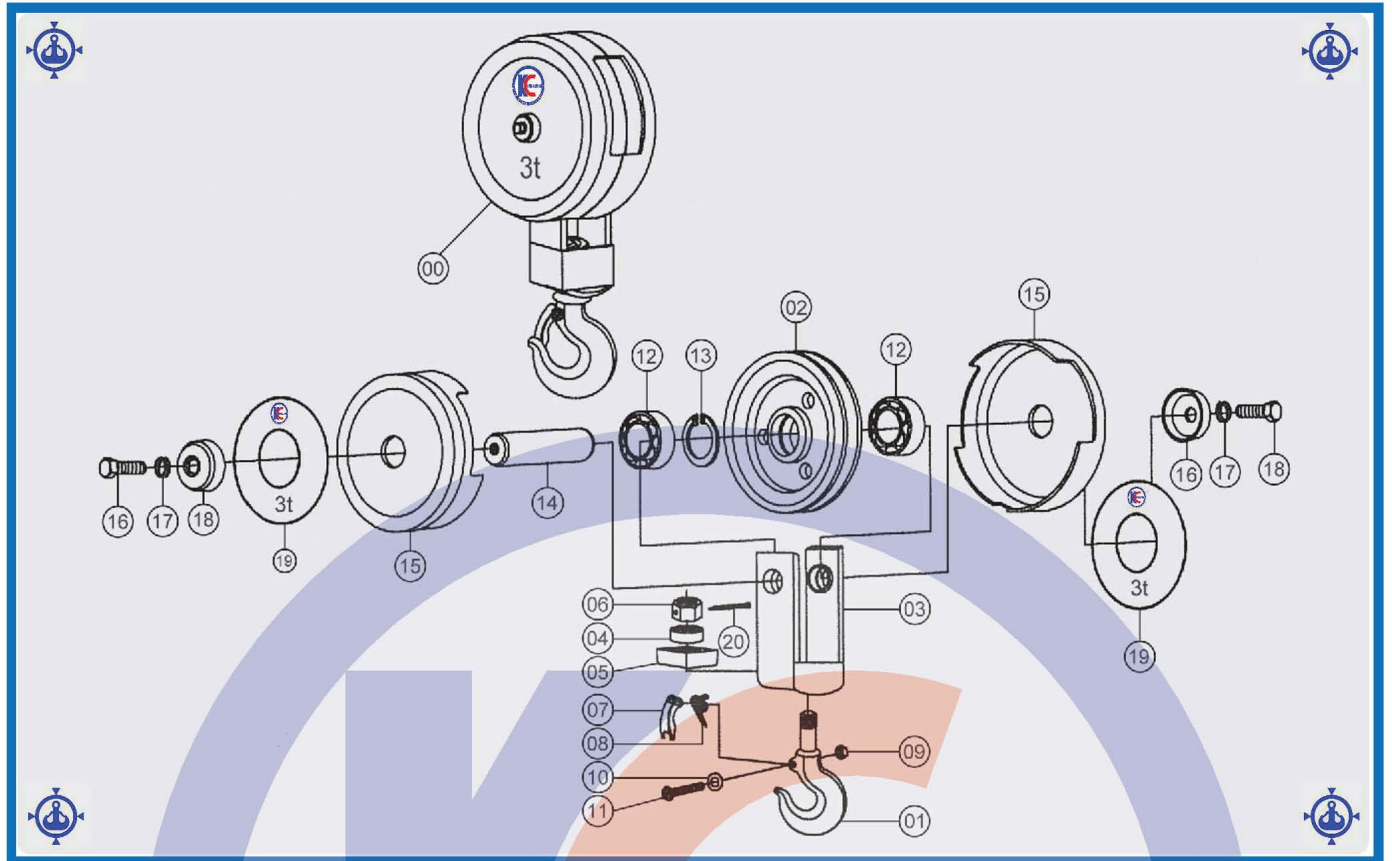

## Load Block Ass'y

### 3TON(Mono-Rail Type)

KEY NO.	PART NO.	PART NAME	Q'TY	REMARKS	KEY NO.	PART NO.	PART NAME	Q'TY	REMARKS
00	314 100	Load Block Ass'y	1		12	314 151	Bearing	2	#6308ZZ
01	314 101	Hook	1		13	214 253	Snap Ring	1	R90
02	314 102	Sheave	1		14	314 100	Sheave Shaft	1	
03	314 103	Frame	1		15	314 111	Sheave Cover	2	
04	214 251	Thrust Bearing	1	#51207	16	314 112	Bolt Cap	2	
05	314 105	Bearing Cap	1		17	211 051	Spring Washer	2	M16
06	314 106	Hook Nut	1		18	214 154	Bolt	2	M16x25L
07	214 107	Safety Latch	1		19	314 113	Name Plate	2	
08	214 108	Spring	1		20	214 155	Split Pin	1	Φ6x70L
09	014 152	Nut	1	M5					
10	014 153	Plate Washer	1	M5					
11	014 154	(+)Screw	1	M5x30L					

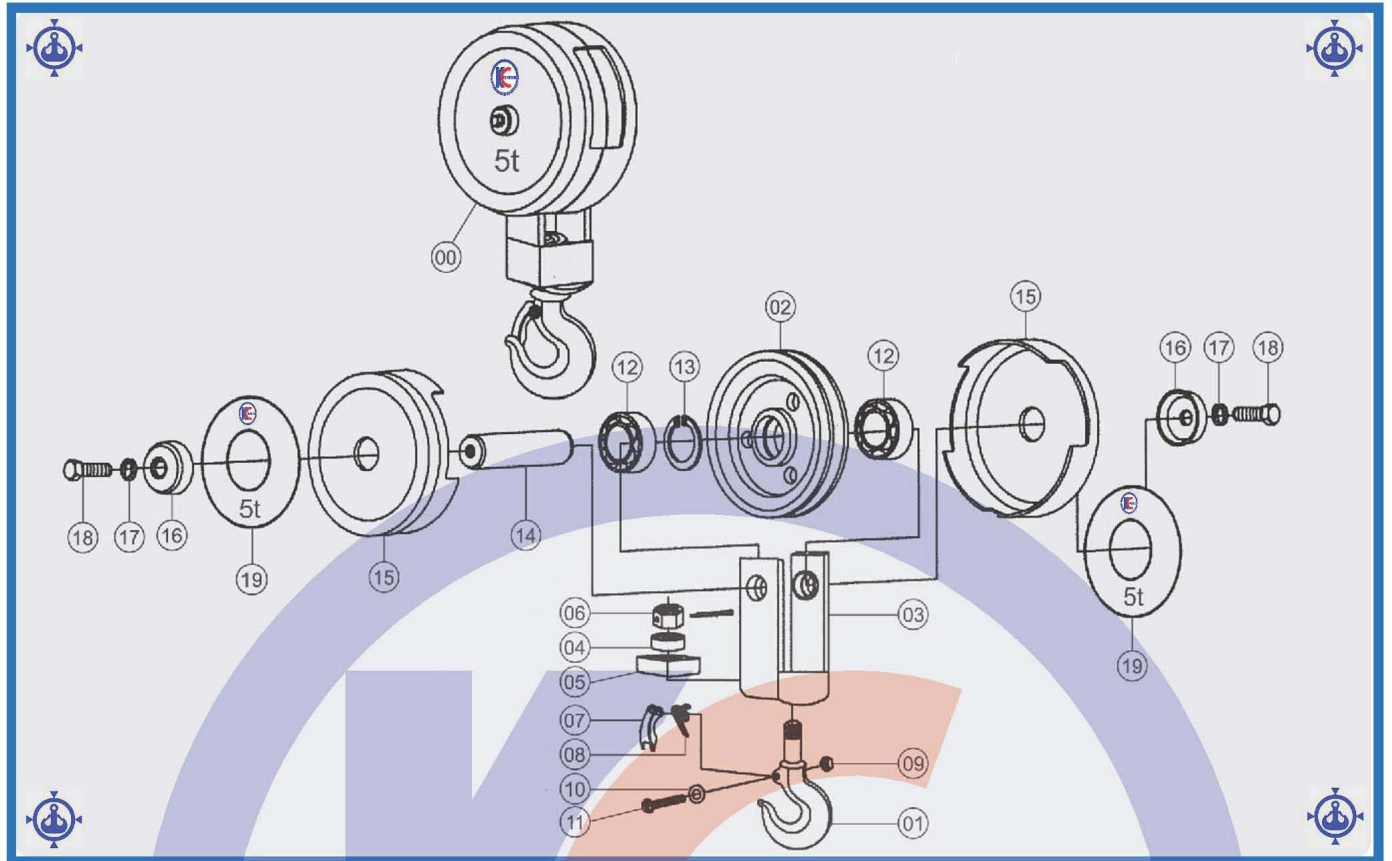

## Load Block Ass'y

### 5TON(Mono-Rail Type)

KEY NO.	PART NO.	PART NAME	Q'TY	REMARKS	KEY NO.	PART NO.	PART NAME	Q'TY	REMARKS
00	414 100	Load Block Ass'y	1		12	414 152	Bearing	2	#6310ZZ
01	414 101	Hook	1		13	414 153	Snap Ring	1	R110
02	414 102	Sheave	1		14	414 110	Sheave Shaft	1	
03	414 103	Frame	1		15	414 111	Sheave Cover	2	
04	414 151	Thrust Bearing	1	#51109	16	414 112	Bolt Cap	2	
05	414 105	Bearing Cap	1		17	211 051	Spring Washer	2	M16
06	414 106	Hook Nut	1		18	412 054	Bolt	2	M16x35L
07	214 107	Safety Latch	1		19	414 113	Name Plate	2	
08	214 108	Spring	1		20	414 154	Split Pin	1	
09	014 152	Nut	1	M5					
10	014 153	Plate Washer	1	M5					
11	014 154	(+)Screw	1	M5x30L					

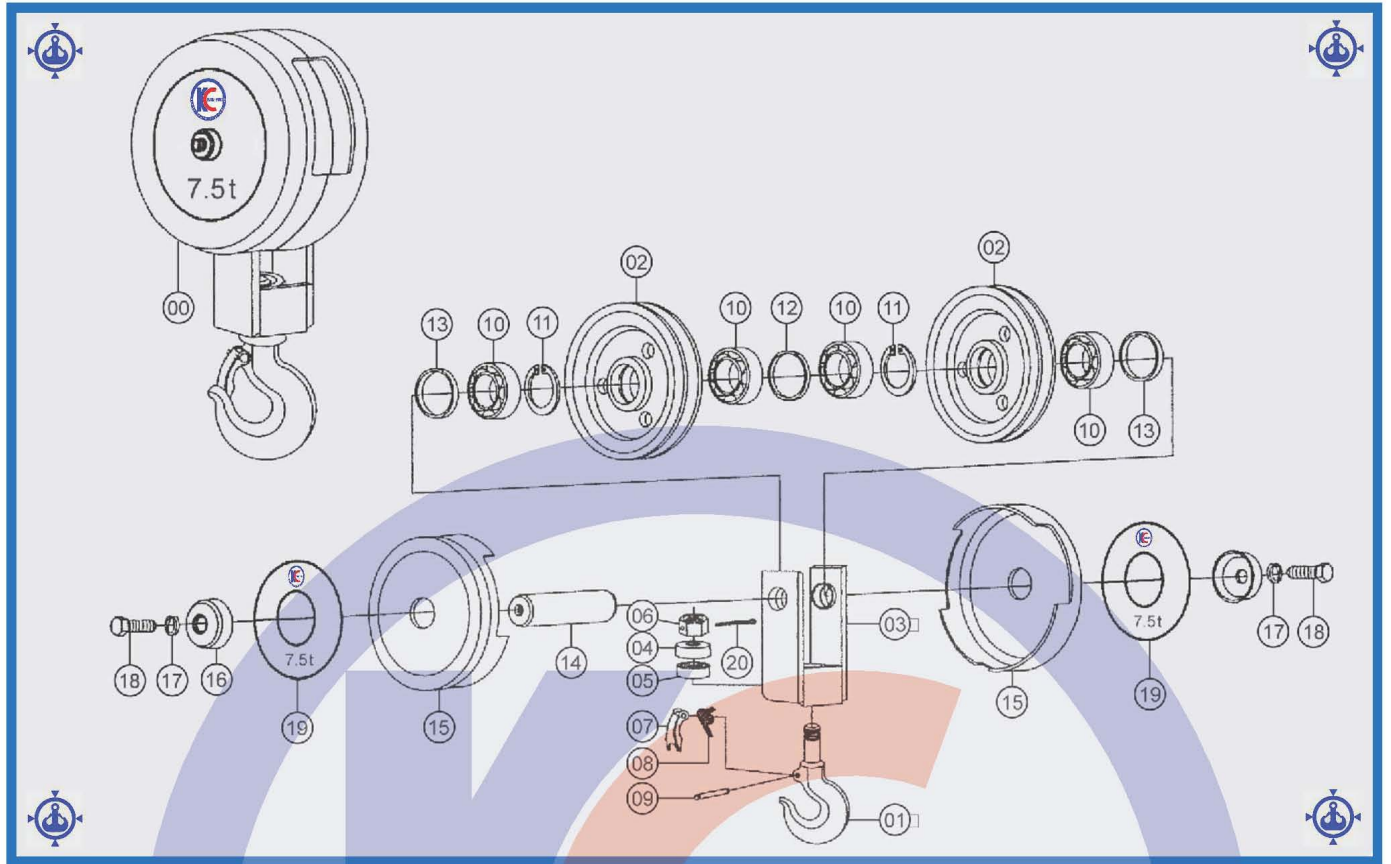

## Load Block Ass'y

### 7.5TON(Mono-Rail & Double Rail Type)

KEY NO.	PART NO.	PART NAME	Q'TY	REMARKS	KEY NO.	PART NO.	PART NAME	Q'TY	REMARKS
00	514 100	Load Block Ass'y	1		12	514 115	Collar	1	
01	514 101	Hook	1		13	514 116	Collar	2	
02	514 102	Sheave	2		14	514 100	Sheave Shaft	1	
03	514 103	Frame	1		15	514 111	Sheave Cover	2	
04	514 105	Bearing Cap	1		16	514 112	Bolt Cap	2	
05	514 151	Thrust Bearing	1	#51214	17	021 155	Spring Washer	2	M24
06	514 106	Hook Nut	1		18	514 156	Bolt	2	M24x50L
07	514 107	Safety Latch	1		19	514 113	Name Plate	2	
08	514 108	Spring	1		20	414 154	Split Pin	1	
09	514 114	Split Pin	1						
10	514 152	Bearing	4	#6212ZZ					
11	414 153	Snap Ring	2	R110					

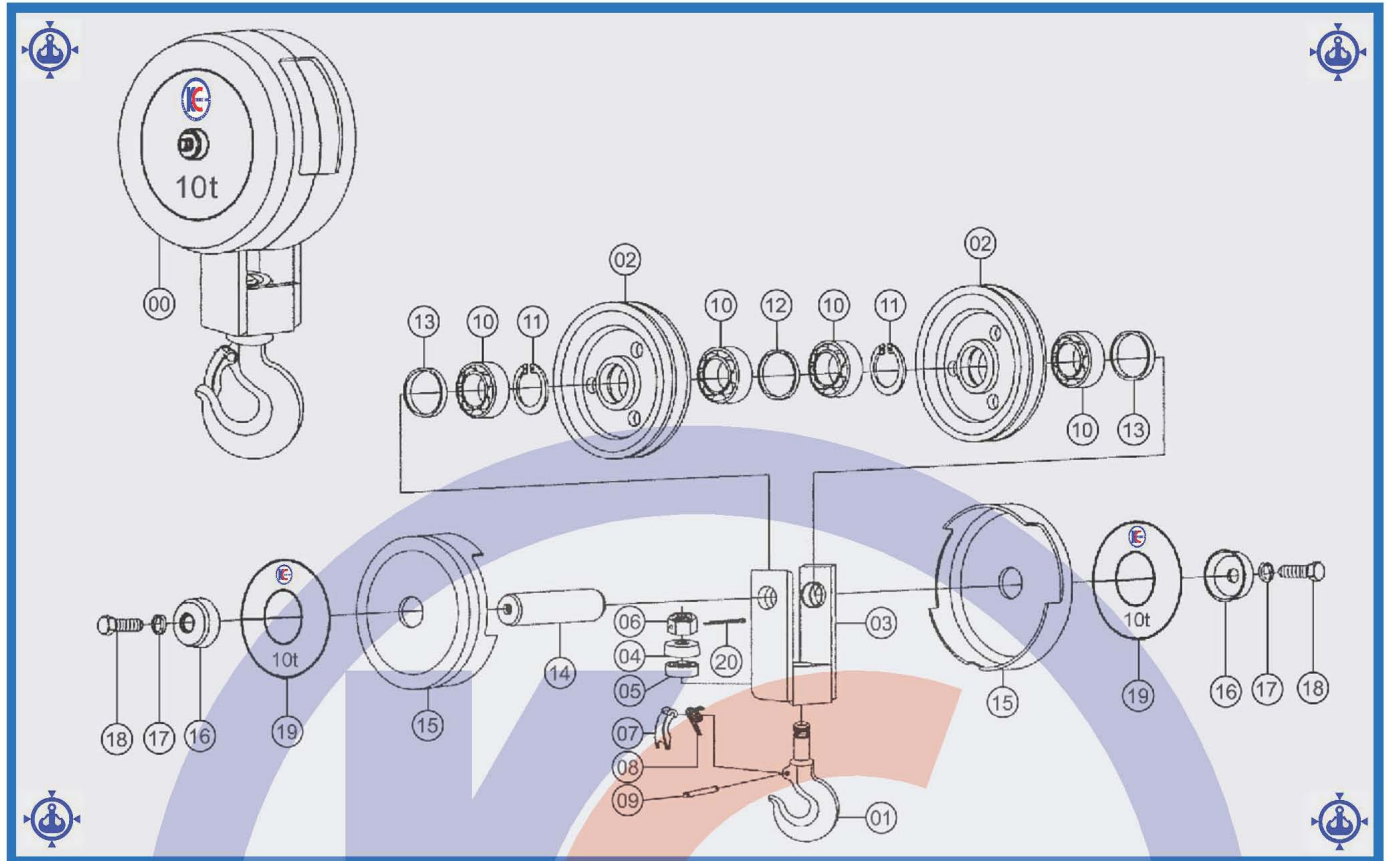

## Load Block Ass'y

### 10TON(Mono-Rail & Double Rail Type)

KEY NO.	PART NO.	PART NAME	Q'TY	REMARKS	KEY NO.	PART NO.	PART NAME	Q'TY	REMARKS
00	614 100	Load Block Ass'y	1		12	614 115	Collar	1	
01	514 101	Hook	1		13	614 116	Collar	2	
02	514 102	Sheave	2		14	614 100	Sheave Shaft	1	
03	614 103	Frame	1		15	614 111	Sheave Cover	2	
04	514 105	Bearing Cap	1		16	614 112	Bolt Cap	2	
05	514 151	Thrust Bearing	1	#51214	17	021 155	Spring Washer	2	M24
06	514 106	Hook Nut	1		18	614 156	Bolt	2	M24x50L
07	514 107	Safety Latch	1		19	614 113	Name Plate	2	
08	514 108	Spring	1		20	614 154	Split Pin	1	
09	514 114	Split Pin	1						
10	514 152	Bearing	4	#6212ZZ					
11	414 153	Snap Ring	2	R110					

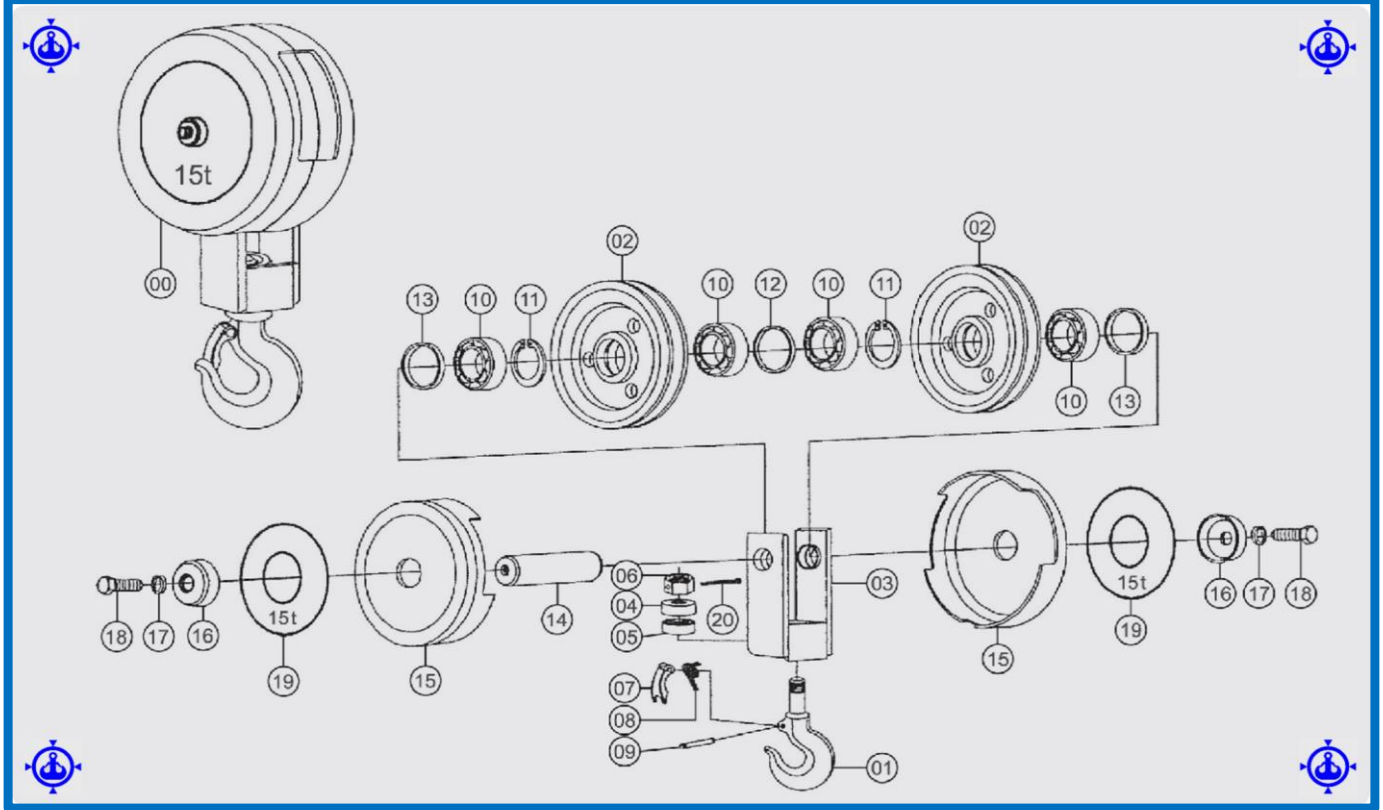

## Load Block Ass'y

### 15TON(Mono-Rail & Double Rail Type)

KEY NO.	PART NO.	PART NAME	Q'TY	REMARKS	KEY NO.	PART NO.	PART NAME	Q'TY	REMARKS
00	714 100	Load Block Ass'y	1		12	714 115	Collar	1	
01	714 101	Hook	1		13	714 116	Collar	2	
02	714 102	Sheave	2		14	714 110	Sheave Shaft	1	
03	714 103	Frame	1		15	714 111	Sheave Cover	2	
04	714 105	Bearing Cap	1		16	714 112	Bolt Cap	2	
05	714 151	Thrust Bearing	1	#51217	17	714 155	Spring Washer	2	M30
06	714 106	Hook Nut	1		18	714 154	Bolt	2	M30x60L
07	714 107	Safety Latch	1		19	714 113	Name Plate	2	
08	514 108	Spring	1		20	714 155	Split Pin	1	
09	514 114	Split Pin	1						
10	714 152	Bearing	4	#6216ZZ					
11	714 153	Snap Ring	2	R140					

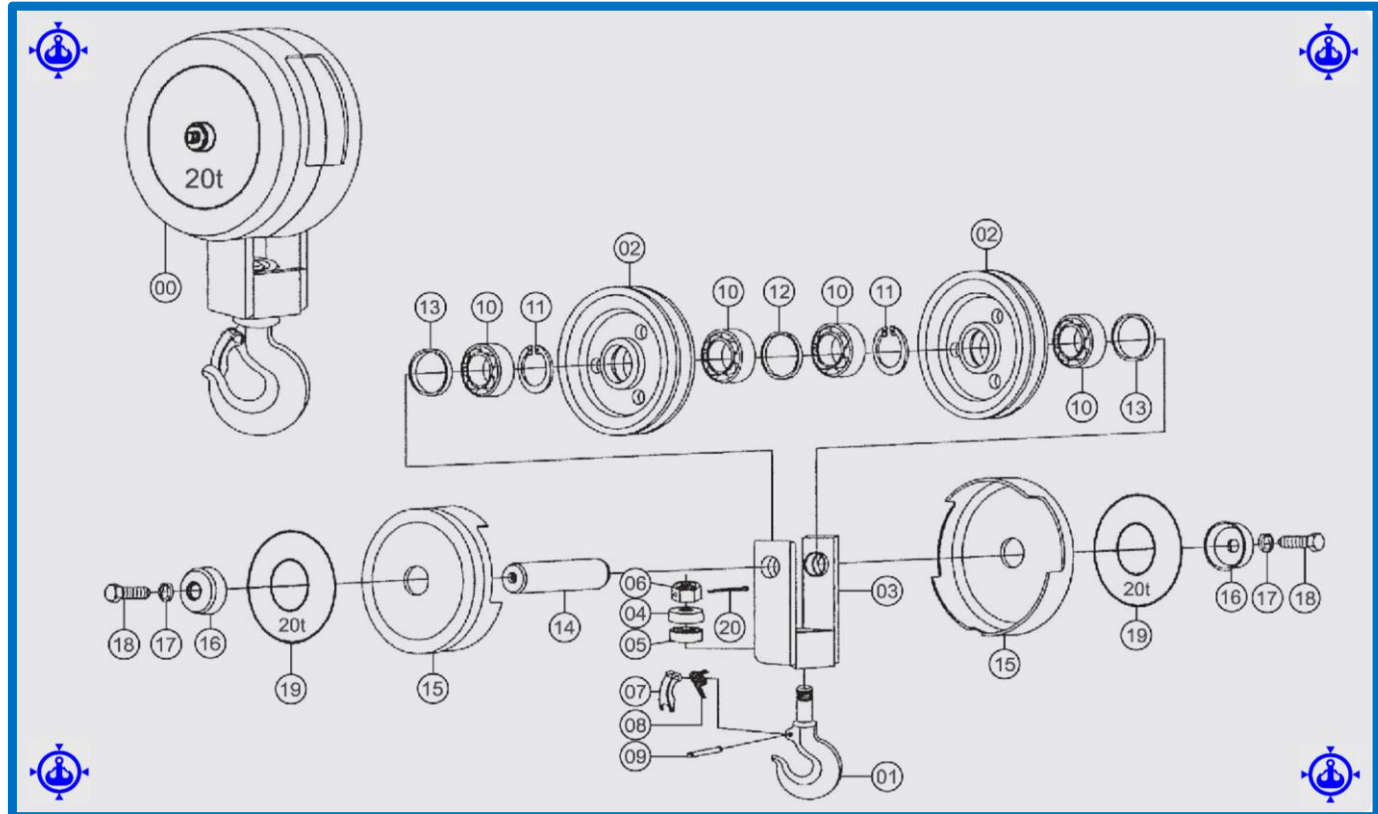

## Load Block Ass'y

### 20TON(Mono-Rail & Double Rail Type)

KEY NO.	PART NO.	PART NAME	Q'TY	REMARKS	KEY NO.	PART NO.	PART NAME	Q'TY	REMARKS
00	814 100	Load Block Ass'y	1		12	814 115	Collar	1	
01	814 101	Hook	1		13	814 116	Collar	2	
02	814 102	Sheave	2		14	814 110	Sheave Shaft	1	
03	814 103	Frame	1		15	814 111	Sheave Cover	2	
04	714 105	Bearing Cap	1		16	814 112	Bolt Cap	2	
05	714 151	Thrust Bearing	1	#51217	17	222 155	Spring Washer	2	M30
06	814 106	Hook Nut	1		18	714 154	Bolt	2	M30x60L
07	714 107	Safety Latch	1		19	814 113	Name Plate	2	
08	514 108	Spring	1		20	814 155	Split Pin	1	
09	514 114	Split Pin	1						
10	814 151	Bearing	4	#6218ZZ					
11	814 152	Snap Ring	2	R160					



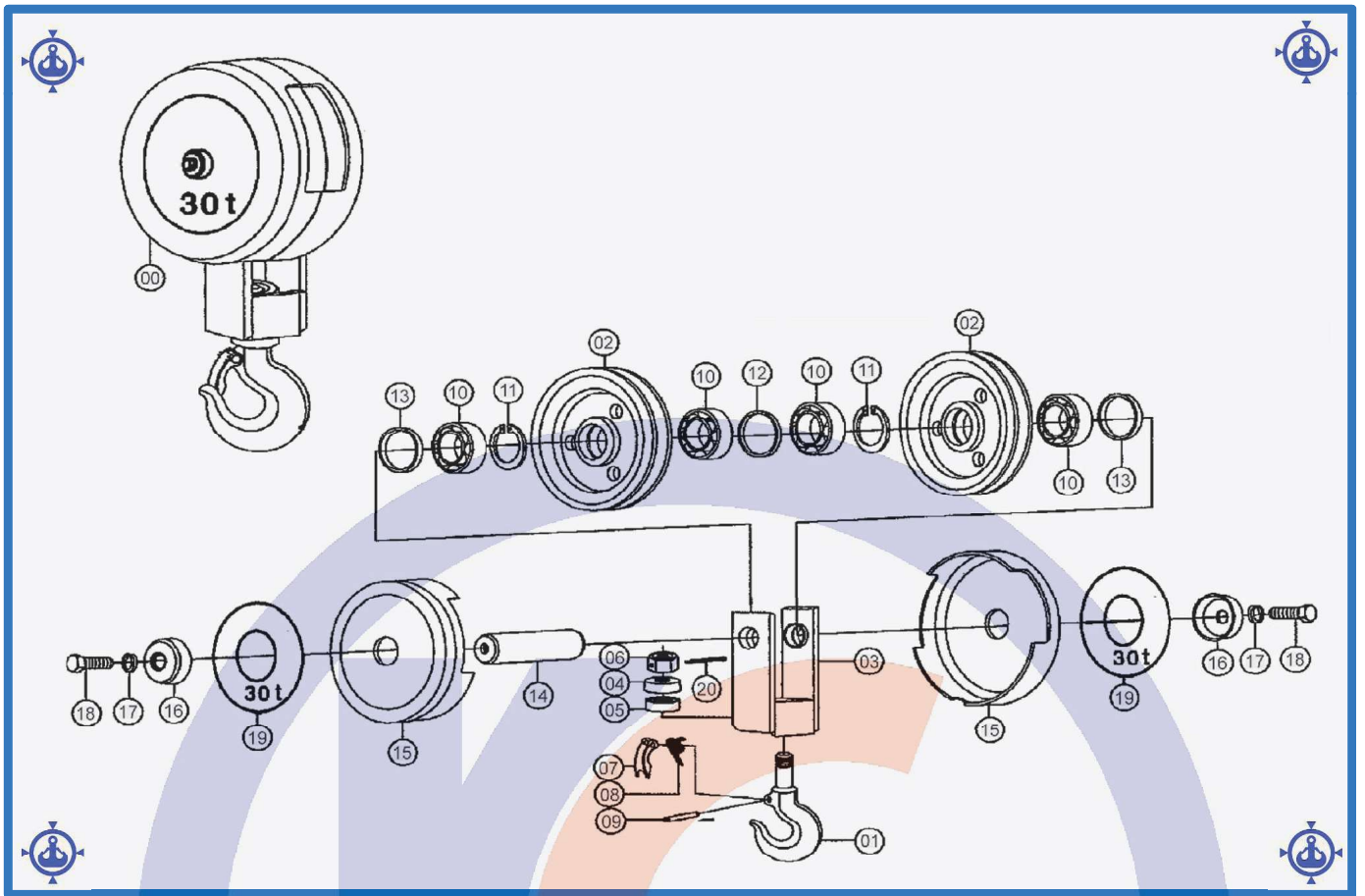

## Load Block Ass'y

**30TON**

KEY NO.	PART NO.	PART NAME	Q'TY	REMARKS	KEY NO.	PART NO.	PART NAME	Q'TY	REMARKS
00	814 300	Load Block Ass'y	1		11	814 152	Snap Ring	3	R160
01	814 301	Hook	1		12	814 315	Collar	1	
02	814 102	Sheave	3	30Ton	13	814 316	Collar	2	
03	814 303	Frame	1	30Ton	14	814 310	Sheave Shaft	1	30Ton
04	814 105	Bearing Cap	1	30Ton	15	814 311	Sheave Cover	2	30Ton
05	814 151	Thrust Bearing	1	#51322	16	814 112	Bolt Cap	2	
06	814 306	Hook Nut	1		17	222 155	Spring Washer	2	M30
07	714 17	Safety Latch	1		18	714 154	Bolt	2	M30x60L
08	514 108	Spring	1		19	814 313	Name Plate	2	
09	514 114	Split Pin	1		20	814 355	Split Pin	1	
10	814 151	Bearing	6	#6218ZZ					