

CRANE COMPONENT : TRAVELLING WHEEL

Overhead Type Wheel

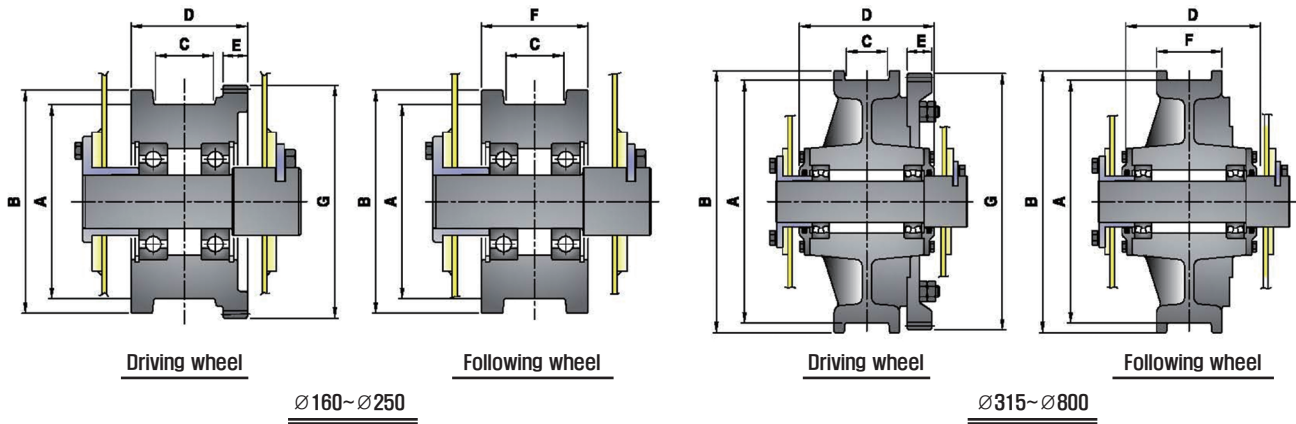

Wheel										Gear		Pinion		Application	Weight
A(mm)	B(mm)	C(mm) (15/30 kg/m)	D(mm)	E(mm)	F(mm)	G(mm)	Bearing	Material	Module & Teeth	Material	Module & Teeth	Material	Motor(kWxP)	4ea (kg)	
160	190	63/72	120	25	110	200	6310ZZ	S45C	M4x48T	S45C	M4x16T	S45CN (Hs 55~60)	0.5x6/0.75x4	160	
200	230	63/72	120	25	110	6311ZZ	M4x58T		M4x16T		230				
250	280	63/72	120	25	110	295	6312ZZ		M5x57T		M5x15T		330		
315	355	63/72	176	30	127	360	#22213	SCMn2A	M5x70T	SC49	M5x15T	1.0x6/1.5x4	440		
400	440	85	260	50	130	432	#22215		M6x70T		M6x19T		750		
500	540	90	278	50	135	528	#22217		M6x86T		M6x19T	1140			
630	670	90	304	60	135	680	#22220		M8x83T		M8x16T	1490			
710	750	90	324	60	135	730	#22222		M10x71T		M10x12T	1810			
800	840	90	350	70	140	820	#22224		M10x80T		M10x12T	2560			
															2.2x6/3.7x4 3.7x6/5.5x4

Suspension Type Wheel

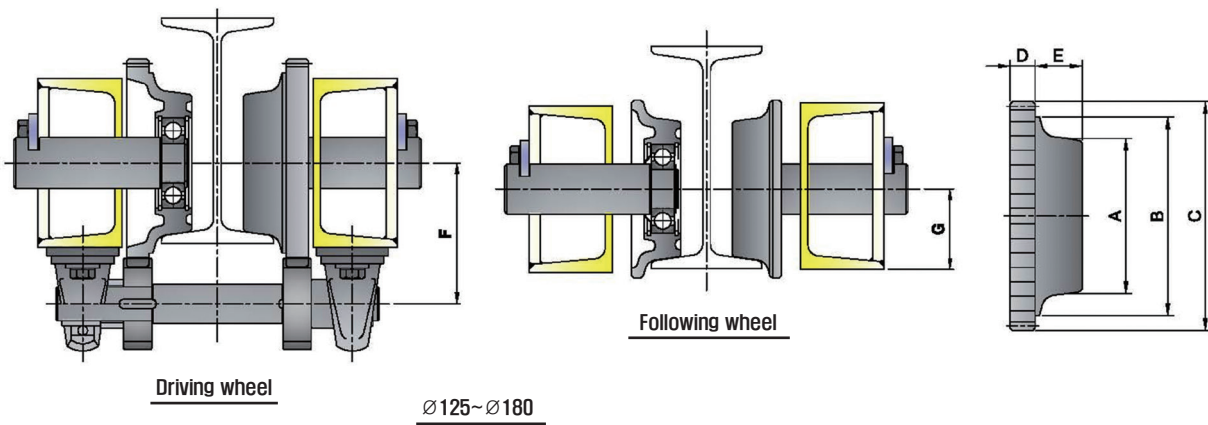

Wheel									Gear		Pinion		Application	Weight
A(mm)	B(mm)	C(mm)	D(mm)	E(mm)	F(mm)	G(mm)	Bearing	Material	Module & Teeth	Material	Module & Teeth	Material	Motor(kWxP)	4ea (kg)
125	160	185	20	38	125	75	6207ZZ	S45CN	M4x43T	S45CN	M4x17T	S45CN (Hs 55~60)	0.5x6/0.75x4	95
160	200	239	20	54	150	6209ZZ	M4x56T		M4x17T		200			
180	220	248	25	64	161.5	100	6212ZZ		M5x49T		M5x14T		255	