

Jib Crane

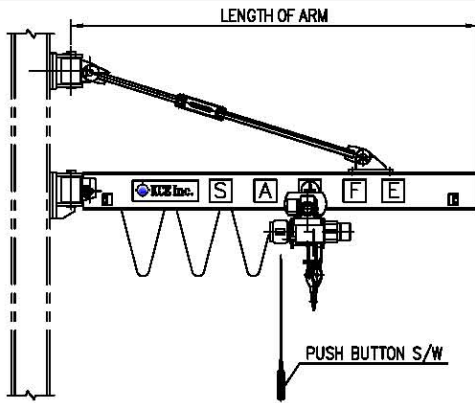

1. Wall Fixed Jib Crane



2. Wall Travelling Jib Crane

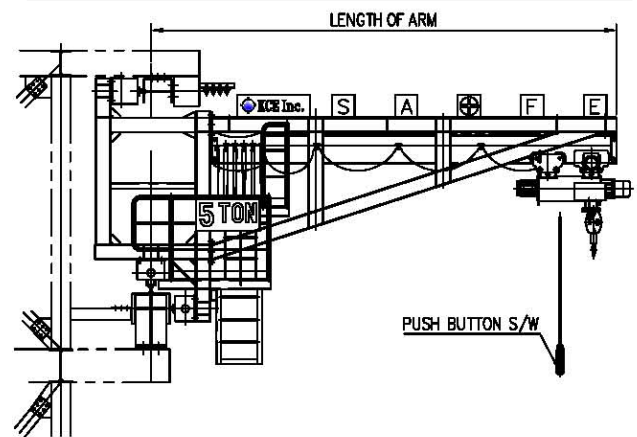

3. Pillar-Mounted Slewing Jib Crane(A)

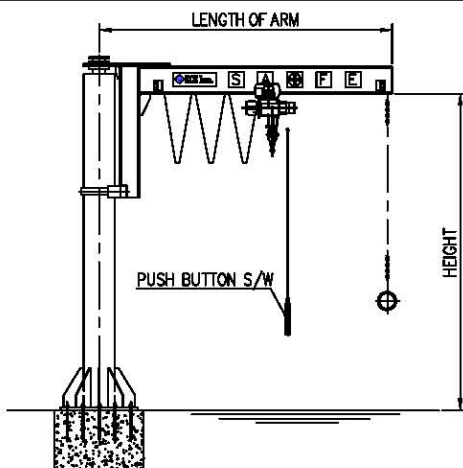

4. Pillar-Mounted Slewing Jib Crane(B)

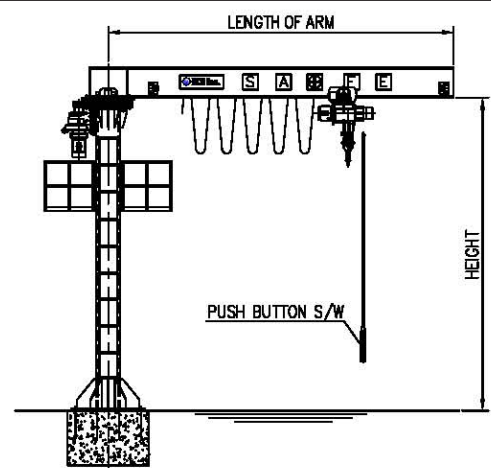

Wall Fixed Jib Crane		
Capacity	0.5ton~3ton	
Working Area	min.	0.8m
	max.	6m
Traversing Speed	16m/min	
Slewing	speed	Manual
	angle	180°

Wall Travelling Jib Crane			
Capacity		0.5ton~10ton	
Working Area	max.		6m
	Traversing Speed		
Travelling Speed			16m/min

Pillar-Mounted Slewing Jib Crane(A)		
Capacity	0.5ton~3ton	
Working Area	min.	0.8m
	max.	6m
Traversing Speed	16m/min	
Slewing	speed	Manual
	angle	360°
Height of Post	Max. 10m	

Pillar-Mounted Slewing Jib Crane(B)			
Capacity		0.5ton~10ton	
Working Area	min.	0.8m	
	max.	6m	
Traversing Speed		16m/min	
Slewing	speed	0.5rpm	
	angle	360°	
Height of Post		max. 10m	