

Foot Mounted Type Hoist (Creep)

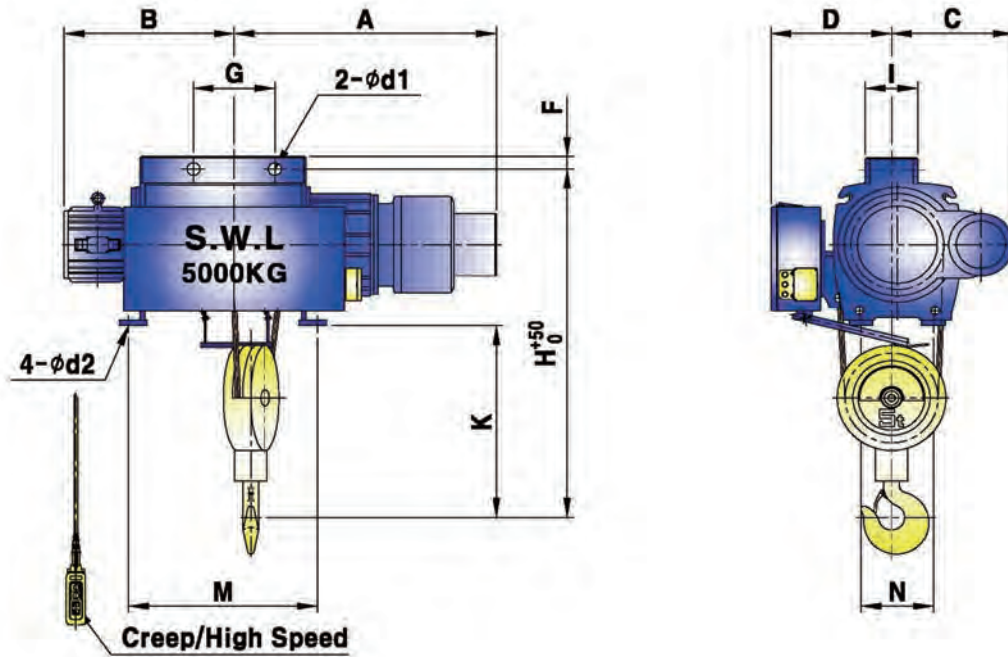

Capacity (ton)		1	2	3	5	7.5	10	15	20	
Model No.		NF01-C-H06	NF02-C-H06	NF03-C-H06	NF05-C-H06	NF075-C-H12	NF10-C-H12	NF15-C-H12	NF20-C-H12	
Hoisting	Lift Height (m)	6 (12)	6 (12)	6 (12)	6 (12)	12	12	12	12	
	Speed (m/min)	50 (Hz)	10/1	8.4/0.84	7.5/0.75	4.7/0.47	3.1/0.31	3.7/0.37	3.7/0.37	3.5/0.35
		60 (Hz)	12/1.2	10/1	9/0.9	5.6/0.56	3.8/0.38	4.5/0.45	4.5/0.45	4.2/0.42
	Motor (kWxP)	2.4/0.4x4	3.7/0.4x4	5.5/1.1x4	5.5/1x6	5.5/1x6	9/1.1x8	13/1.8x8	17/1.8x8	
	Wire Rope (∅xFalls)	Construction	6x37	6x37	6x37	6x37	6x37	6x37	6x37	6x37
Dia.(mm) x No. of ropes		8x2	10x2	12.5x2	16x2	14x4	16x4	20x4	22.4x4	
Brake		DC Magnet Disc Brake								
Dimension (approx.) (mm)	H	750	920	1060	1245	1270	1330	1660	1900	
	A	580 (680)	620 (720)	740 (840)	840 (940)	1170	1230	1365	1460	
	B	380 (480)	410 (510)	440 (540)	500 (585)	835	955	1005	1220	
	C	330	370	375	430	465	525	575	621	
	D	275	310	365	415	480	510	620	640	
	F	28	34	30	45	50	50	65	65	
	G	160	200	200	280	800	800	800	850	
	I	112	150	150	180	232	232	272	272	
	K	360	470	560	690	720	740	965	1150	
	M	350 (550)	350 (550)	364 (564)	450 (650)	1100	1100	1150	1250	
	N	150	200	200	250	400	400	500	500	
	d1	26	33	33	47	47	47	63	63	
d2	17	17	17	17	25	25	25	25		
Weight (approx.) (kg)		195 (225)	246 (282)	330 (370)	518 (585)	760	1080	1680	1950	

Note : 1) Figures in parentheses are for Hoists of 12-meter lift spacers. 2) Please make a contact about hoist with over 12m lift length.